

LaserCam-HR II

High-Resolution Laser Beam Profiling System

LaserCam-HR II is our second generation of digital USB 2.0 bus-powered, high-resolution, large-area cameras. The LaserCam-HR II family includes 1/2-inch and 2/3-inch format CCD cameras that provide greater dynamic range and lower noise than the previous generation. The cameras include Coherent's BeamView software package, long recognized as a flexible, fast, and user friendly beam diagnostics software platform. The UV model provides long-term UV sensor stability.



FEATURES & BENEFITS

- USB 2.0, 12-bit and 14-bit digital output
- Large-area arrays
- Compact 68 x 68 x 43 mm package
- Metric and English mounts included
- CW and pulsed operation including external triggering
- Variable exposure time
- User-variable trigger delay
- C-mount thread for additional accessories

OPTIONS & ACCESSORIES

- Scientific
- UV Lasers
- Telecommunication Sources
- Military Laser Systems

SPECIFICATIONS ¹	LaserCam-HR II 1/2-inch	LaserCam-HR II 2/3-inch	LaserCam-HR II UV 2/3-inch
Sensor Elements (pixels)	1280 x 1024		
Effective Pixel Resolution (µm)	n/a	n/a	20 x 20
Pixel Size (µm)	4.6 x 4.6	6.5 x 6.5	n/a
Sensor Active Area (mm) (H x V)	5.9 x 4.8	8.3 x 6.6	8.3 x 6.6
Camera Bit Depth	12-bit	14-bit	14-bit
Spectral Range (nm)			
without LDFP	190 to 1100 ¹	190 to 1100 ¹	190 to 355
with LDFP included	400 to 1100	400 to 1100	
with BIP-12F accessory	190 to 355	190 to 355	
Recommended Beam Diameters (mm)	0.15 to 4.0 ²	0.2 to 6.0 ²	0.5 to 6.0
Capture Modes	Continuous (CW), pulsed		
Variable Exposure Time	1 msec to 500 msec, default at 5 msec	1 msec to 500 msec, default at 5 msec	1 msec to 500 msec, default at 5 msec
Trigger Delay (µs)	75	20	20
Maximum Pulse Trigger in Rate ³ (Hz)	200	200	200
Damage Threshold			
without LDFP	32 mJ/cm ² at 1064 nm	32 mJ/cm ² at 1064 nm	200 µJ/cm ² at 1064 nm ⁴
CW Saturation			
with LDFP	13 mW/cm ² at 633 nm	5 mW/cm ² at 633 nm	90 mW/cm ² at 248 nm ⁵
without LDFP	5 µW/cm ² at 633 nm	2 µW/cm ² at 633 nm	90 µW/cm ² at 248 nm ⁴
with LDFP	70 mW/cm ² at 1064 nm	25 mW/cm ² at 1064 nm	
without LDFP	340 µW/cm ² at 1064 nm	125 µW/cm ² at 1064 nm	
Pulsed Saturation			
with LDFP	0.4 mJ/cm ² at 1064 nm	0.15 mJ/cm ² at 1064 nm	5 mJ/cm ² at 248 nm ⁵
without LDFP	2 µJ/cm ² at 1064 nm	0.7 µJ/cm ² at 1064 nm	5 µJ/cm ² at 248 nm ⁴
USB 2.0 Cable	10 ft. standard A/B cable included		
Trigger	Connector BNC receptacle (trigger cable included)		
Part Number	1282868	1282870	1360550

¹ There is a risk of degradation in the range of 190 nm to 300 nm due to DUV exposure. The optional BIP-12F UV-to-visible fluorescence converter can be used to prevent drift.

² It is possible to measure beams <0.2 mm in diameter, but resolution is reduced.

³ Without averaging adjacent pulses.

⁴ Without LDFP-UV.

⁵ With LDFP-UV.

MECHANICAL SPECIFICATIONS

LaserCam-HR II

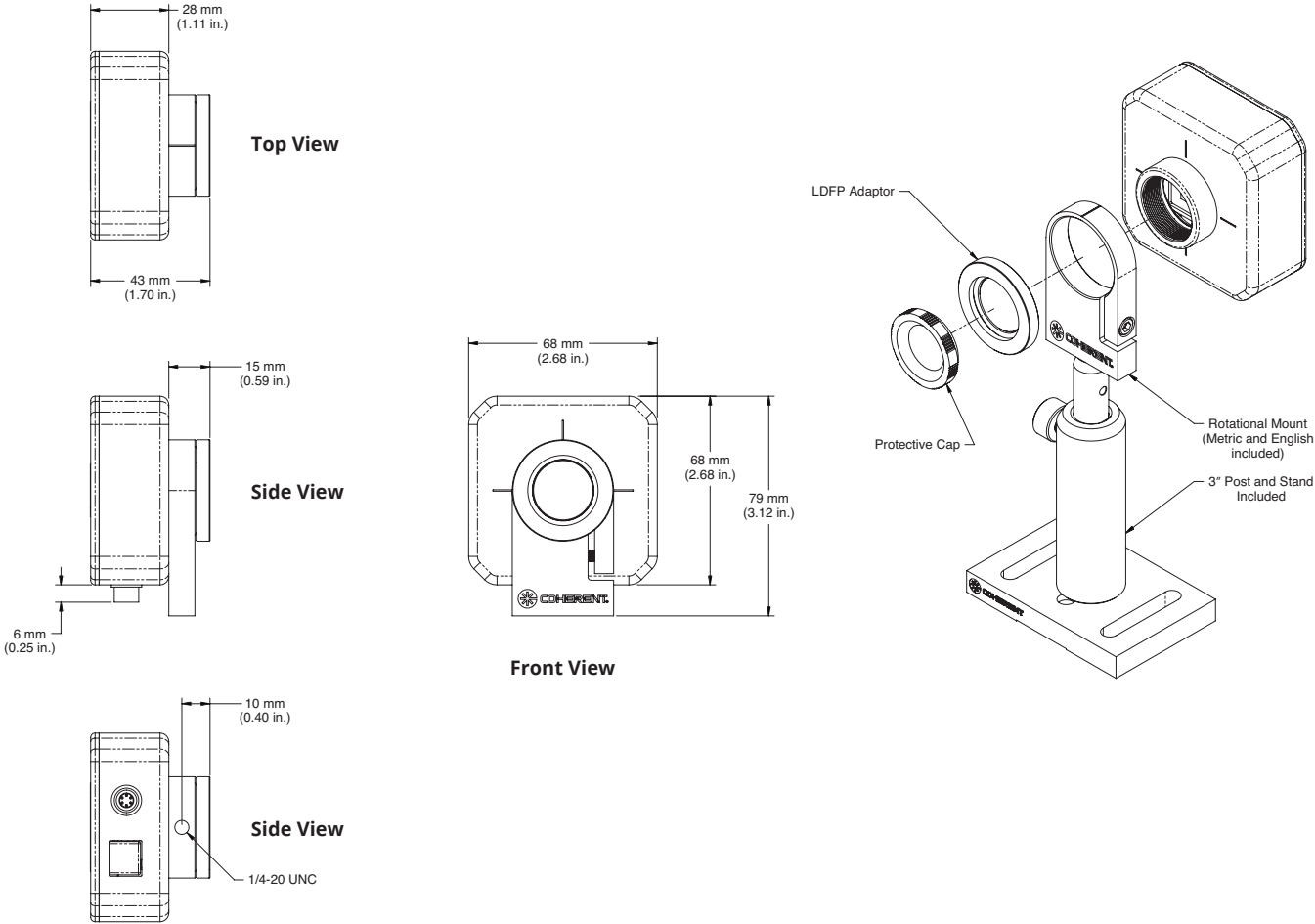

扫一扫
添加客服微信



上海彩莹科技有限公司
咨询热线：18612117394
邮箱：contact@colour-fly.com
www.colour-fly.com

Coherent follows a policy of continuous product improvement. Specifications are subject to change without notice. Coherent's scientific and industrial lasers are certified to comply with the Federal Regulations (21 CFR Subchapter J) as administered by the Center for Devices and Radiological Health on all systems ordered for shipment after August 2, 1976.

Coherent offers a limited warranty for all LaserCam-HR II Beam Diagnostic Cameras. For full details of this warranty coverage, please refer to the Service section at www.Coherent.com or contact your local Sales or Service Representative. MC-135-02-0M0318Rev.C Copyright ©2018 Coherent, Inc.