



Water-Cooled Thermopile Sensors to 5 kW

Compact, Water-Cooled Laser Power Sensors

These compact sensors are particularly useful when space is an issue. They must be water-cooled to achieve the full power rating, and they can also be used air-cooled (stand-alone or mounted to a heat sink) for stand-alone intermittent application of power.

FEATURES

- Compact designs
- Use water-cooled or air-cooled
- 19 mm and 50 mm apertures

APPLICATIONS

- Medical
- Scientific
- Industrial
- General Laser Power
Measurement to 5 kW



SPECIFICATIONS	PM10-19C	PM150-19C	PM150-50C	PM300
Wavelength Range (µm)	0.25 to 11			
Power Range (water-cooled)	10 mW to 10 W	300 mW to 150 W	300 mW to 150 W	1 W to 300 W
Maximum Intermittent Power (W) (<5 min.)	5 ¹	20 ¹	80 ¹	450 ²
Long-Pulse Joules Range (J)	0.5 to 10	1 to 150	1 to 150	-
Resolution (mW)	1	30	30	100
Maximum Power Density (kW/cm ²)	6			
Maximum Energy Density (mJ/cm ²)	600, 1064 nm, 10 ns			
Response Time (sec.)	2	2	5	5
Detector Coating	Broadband			
Active Area Diameter (mm)	19	19	50	19
Calibration Uncertainty (%) (k=2)	±1			
Calibration Wavelength (µm)	514			
Cooling Method	Water-cooled			
Cable Type	PM DB-25			
Cable Length (m)	2			
Part Number	1098397	1098444	1098412 ³	1141474

1 This intermittent power rating is for when the sensor is used without water-cooling.
 2 This intermittent power rating is for when the sensor is used with water-cooling.
 3 1 Day Ship program: eligible for next business day shipment.

MECHANICAL SPECIFICATIONS

PM10-19C/PM150-19C

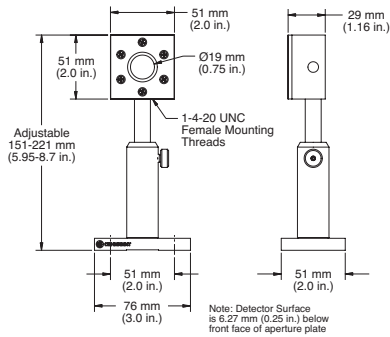

PM150-50C

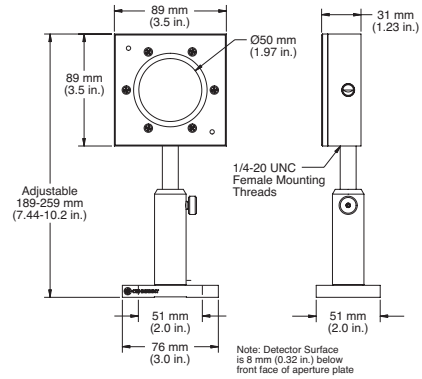

PM300

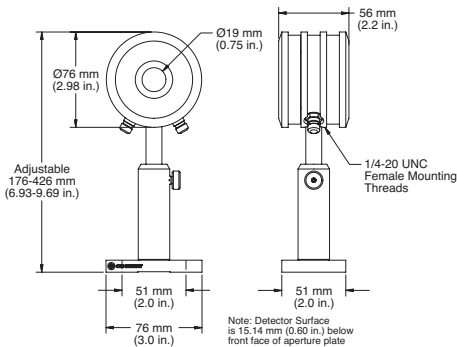

SPECIFICATIONS	PM150X	PM150-50XC
Wavelength Range (µm)	0.15 to 1.064	
Power Range	300 mW to 150 W	
Maximum Intermittent Power (W) (<5 min.)	300	80 (air-cooled)
Long-Pulse Joules Range (J)	1 to 150	
Resolution (mW)	30	
Maximum Power Density (kW/cm ²)	6	
Maximum Energy Density (mJ/cm ²)	600, 1064 nm, 10 ns	
Response Time (sec.)	5	
Detector Coating	UV	
Active Area Diameter (mm)	50	
Calibration Uncertainty (%) (k=2)	±1	
Calibration Wavelength (µm)	514	
Cooling Method	Air-cooled	Water-cooled
Cable Type	PM DB-25	
Cable Length (m)	2	
Part Number	1098455	1098443 ¹

¹ Water fittings are included with PM150-50XC.

MECHANICAL SPECIFICATIONS

PM150X

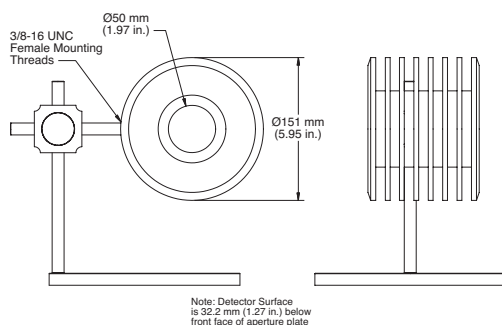

PM150-50XC

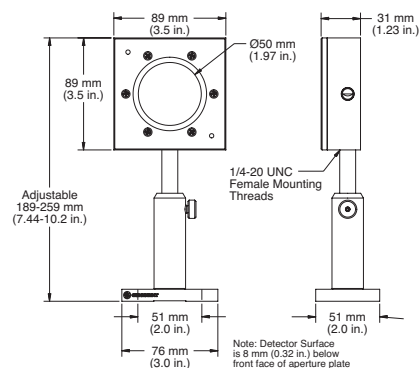

Coherent, Inc.,
 5100 Patrick Henry Drive Santa Clara, CA 95054
 p. (800) 527-3786 | (408) 764-4983
 f. (408) 764-4646

tech.sales@coherent.com www.coherent.com



扫一扫
 添加客服微信



上海彩萤科技有限公司
 咨询热线：18612117394
 邮箱：contact@colour-fly.com
www.colour-fly.com