



Fan-Cooled Thermopile Sensors to 300 W

Fan-Cooled Thermopile Sensors for Measurement of Laser Power up to 300 W

Forced-air, fan-cooled sensors enable measurement of higher powers than passively cooled sensors, and are an excellent choice for measuring high-power lasers when water-cooling is not possible. These sensors allow for continuous power monitoring at 200 W and 300 W with aperture diameters up to 50 mm (depending upon model).

In conjunction with their compact size, ease of portability makes fan-cooled sensors particularly useful for field service or production test applications.

A compact wall-mount power supply provides the 12 VDC required to power the low-noise, brushless fan motor.

FEATURES & BENEFITS

- Maximum powers from 200 W to 300 W
- Minimum power down to 1 W
- Broadband and Excimer coatings
- Fan-cooled
- 0.25 μm to 11 μm spectral range
- 19 mm and 50 mm diameter active areas
- RoHS compliant



Fan-Cooled Thermopile Sensors to 300 W Datasheet

SPECIFICATIONS	PM200F-19	PM200F-50	PM300F-19	PM300F-50
Wavelength Range (μm)	0.25 to 11			
Power Range (W)	1 to 200		1 to 300	
Long-Pulse Joules Range (J)	1 to 200		1 to 300	
Maximum Intermittent Power (<5 min.) (W)	300		450	
Resolution (W)	100			
Maximum Power Density (kW/cm^2)	6			
Maximum Energy Density (mJ/cm^2)	600, 1064 nm, 10 ns			
Response Time (sec.)	2	5	2	5
Detector Coating	Broadband			
Active Area Diameter (mm)	19	50	19	50
Calibration Uncertainty (%) (k=2)	± 1			
Calibration Wavelength (nm)	514			
Cooling Method	Fan-cooled			
Cable Type	PM DB-25			
Cable Length (m)	2			
Part Number	1098480	1098472 ¹	1098509 ¹	1098417

¹ C24 Quick Ship program: eligible for next business day shipment.

MECHANICAL SPECIFICATIONS

PM200F-19/PM200F-50

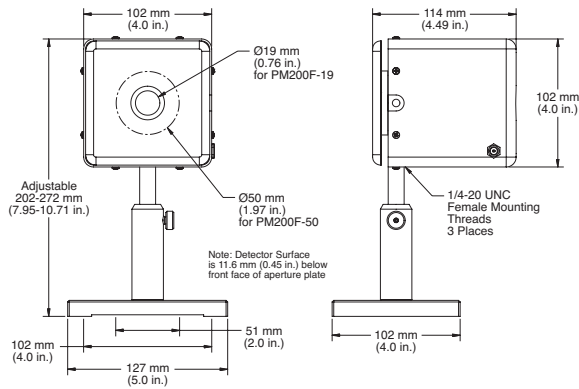

PM300F-19/PM300F-50

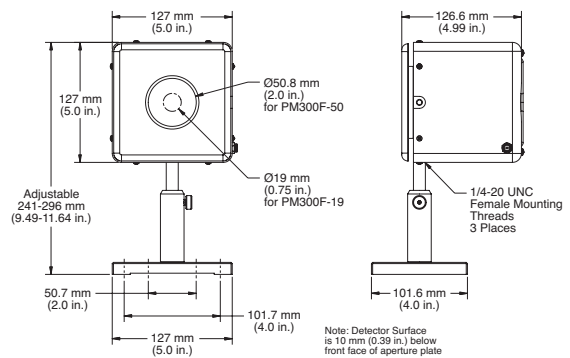

SPECIFICATIONS	PM200F-50X	PM300F-50X
Wavelength Range (µm)	0.15 to 1	
Power Range (W)	1 to 200	1 to 300
Long-Pulse Joules Range (J)	1 to 200	1 to 300
Maximum Intermittent Power (<5 min.) (W)	300	450
Resolution (W)	100	
Maximum Power Density (kW/cm ²)	6	
Maximum Energy Density (mJ/cm ²)	600, 1064 nm, 10 ns	
Response Time (sec.)	5	
Detector Coating	UV	
Active Area Diameter (mm)	50	
Calibration Uncertainty (%) (k=2)	±1	
Calibration Wavelength (nm)	514	
Cooling Method	Fan-cooled	
Cable Type	PM DB-25	
Cable Length (m)	2	
Part Number	1113493	1098481

MECHANICAL SPECIFICATIONS

PM200F-50X

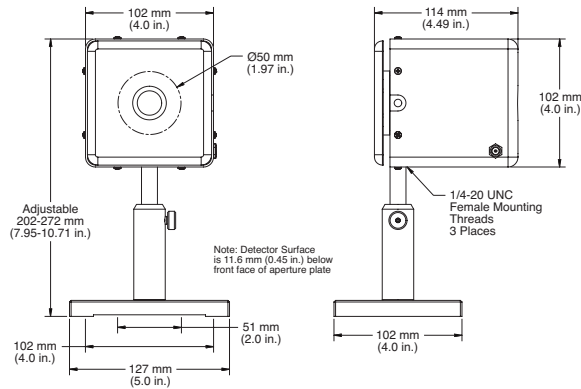

PM300F-50X

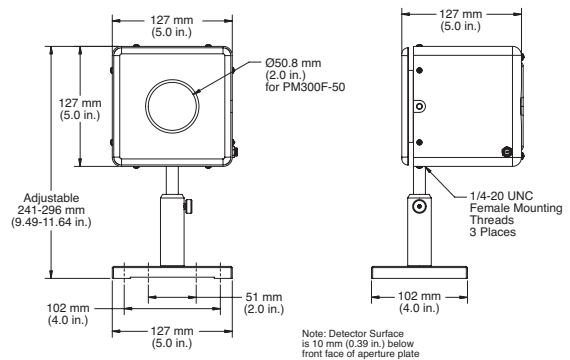

Coherent, Inc.,
 5100 Patrick Henry Drive Santa Clara, CA 95054
 p. (800) 527-3786 | (408) 764-4983
 f. (408) 764-4646

tech.sales@coherent.com www.coherent.com



扫一扫
 添加客服微信



上海彩萤科技有限公司
 咨询热线：18612117394
 邮箱：contact@colour-fly.com
www.colour-fly.com

Coherent follows a policy of continuous product improvement. Specifications are subject to change without notice. Coherent's scientific and industrial lasers are certified to comply with the Federal Regulations (21 CFR Subchapter J) as administered by the Center for Devices and Radiological Health on all systems ordered for shipment after August 2, 1976.

Coherent offers a limited warranty for all High Power Water-Cooled Thermopile Sensors. For full details of this warranty coverage, please refer to the Service section at www.coherent.com or contact your local Sales or Service Representative. MC-047-19-0M1119 Copyright ©2019 Coherent, Inc.